



Changshu Talent
Semiconductors Co.,Ltd
Tel:0086-512-52851998
Fax:0086-512-52153129

1N4942GP THRU 1N4948GP

1 Amp Glass Passivated Fast Recovery Rectifier 200 - 1000 Volts

Features

- Low Leakage Current and Fast Switching
- Epoxy meets UL 94 V-0 flammability rating
- Moisture Sensitivity Level 1
- Glass Passivated Junction
- Lead Free Finish/RoHS Compliant (Note1)

Maximum Ratings

- Operating Temperature: -55°C to +150°C
- Storage Temperature: -55°C to +150°C
- Maximum Thermal Resistance; 50°C/W Junction To Ambient

Catalog Number	Device Marking	Maximum Recurrent Peak Reverse Voltage	Maximum RMS Voltage	Maximum DC Blocking Voltage
1N4942GP	1N4942GP	200V	140V	200V
1N4944GP	1N4944GP	400V	280V	400V
1N4946GP	1N4946GP	600V	420V	600V
1N4947GP	1N4947GP	800V	560V	800V
1N4948GP	1N4948GP	1000V	700V	1000V

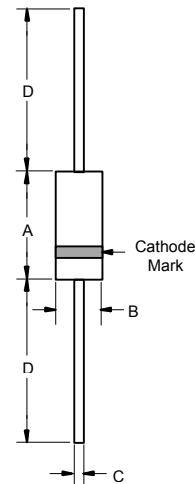
Electrical Characteristics @ 25°C Unless Otherwise Specified

Average Forward Current	$I_{F(AV)}$	1.0A	$T_A = 55^\circ\text{C}$
Peak Forward Surge Current	I_{FSM}	25A	8.3ms, half sine
Maximum Instantaneous Forward Voltage	V_F	1.3V	$I_{FM} = 1.0\text{A};$ $T_A = 25^\circ\text{C}^*$
Maximum DC Reverse Current At Rated DC Blocking Voltage	I_R	5.0 μA 200 μA	$T_J = 25^\circ\text{C}$ $T_J = 150^\circ\text{C}$
Maximum Reverse Recovery Time 1N4942-4944 1N4946-4947 1N4948	T_{rr}	150ns 250ns 500ns	$I_F=0.5\text{A},$ $I_R=1.0\text{A},$ $I_{rr}=0.25\text{A}$
Typical Junction Capacitance	C_J	15pF	Measured at 1.0MHz, $V_R=4.0\text{V}$

*Pulse test: Pulse width 300 μsec , Duty cycle 2%

Note: 1. High Temperature Solder Exemption Applied, see EU Directive Annex 7.

DO-41

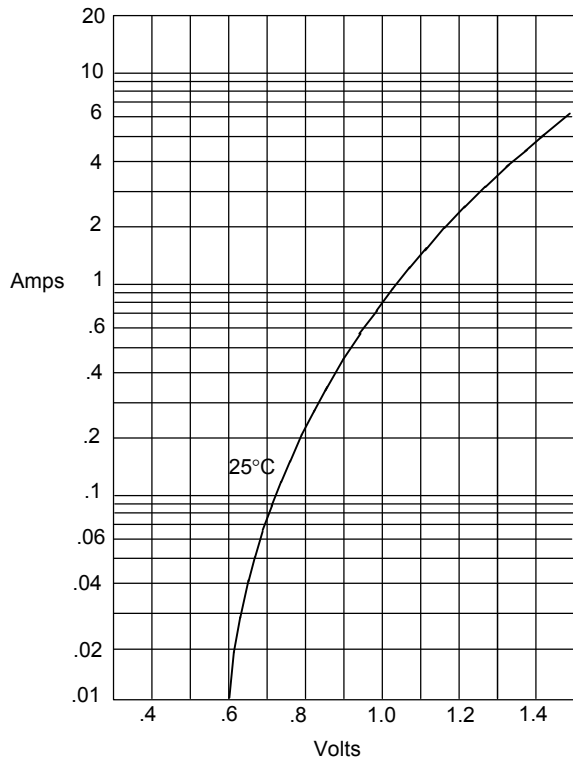


DIM	INCHES		MM		NOTE
	MIN	MAX	MIN	MAX	
A	.166	.205	4.10	5.20	
B	.080	.107	2.00	2.70	
C	.028	.034	.70	.90	
D	1.000	---	25.40	---	

1N4942GP thru 1N4948GP

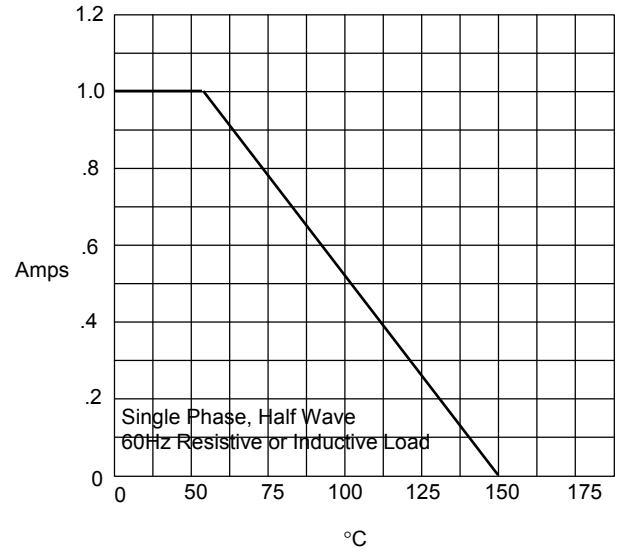


Figure 1
Typical Forward Characteristics



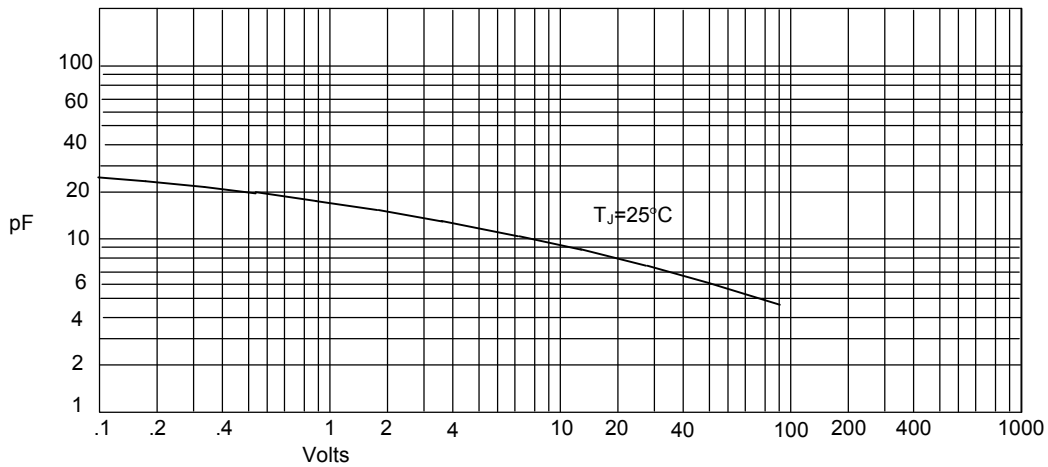
Instantaneous Forward Current - Amperes *versus*
Instantaneous Forward Voltage - Volts

Figure 2
Forward Derating Curve



Average Forward Rectified Current - Amperes *versus*
Ambient Temperature - °C

Figure 3
Junction Capacitance

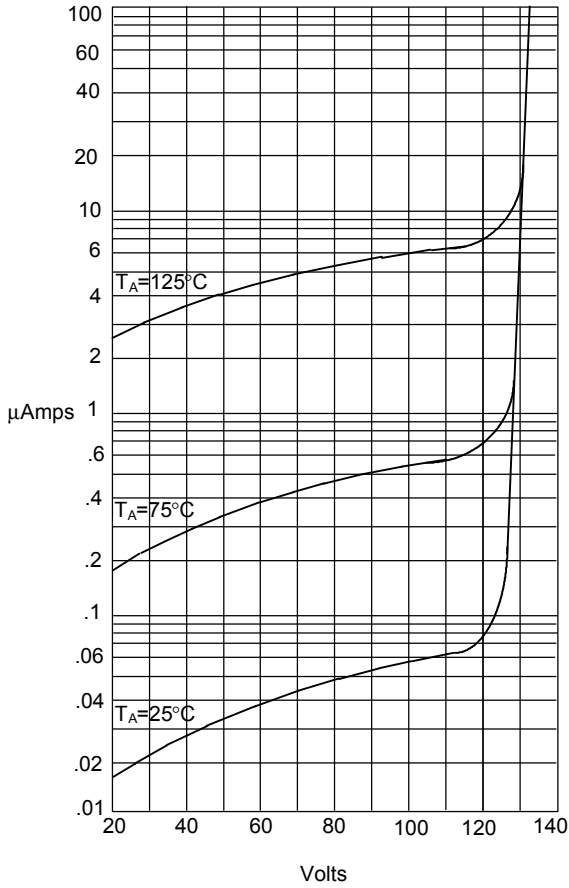


Junction Capacitance - pF *versus*
Reverse Voltage - Volts

1N4942GP thru 1N4948GP

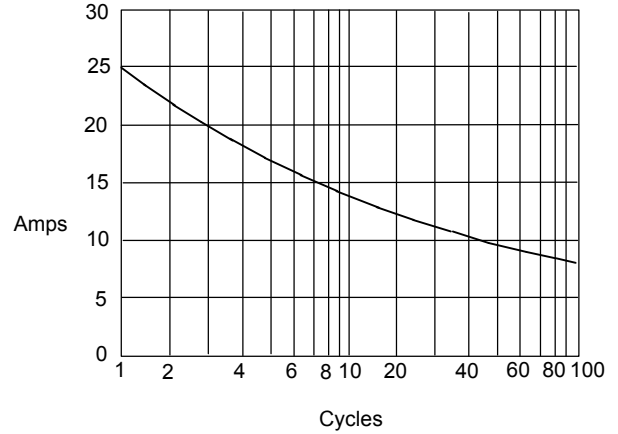


Figure 4
Typical Reverse Characteristics



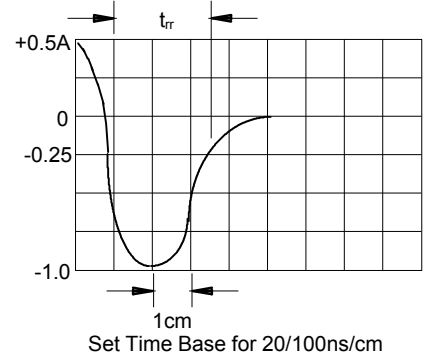
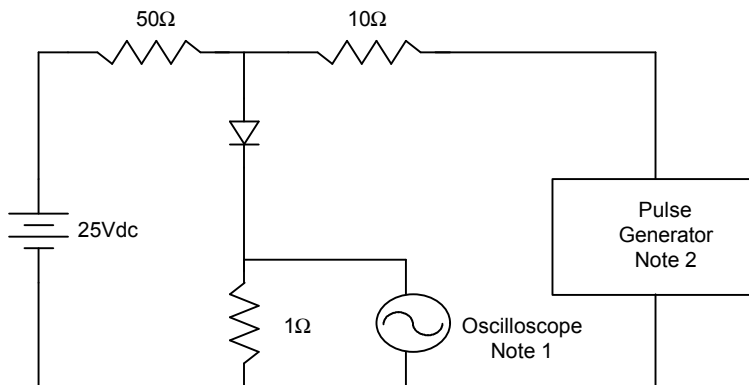
Instantaneous Reverse Leakage Current - MicroAmperes versus
Percent Of Rated Peak Reverse Voltage - Volts

Figure 5
Non-Repetitive Peak Forward Surge Current



Peak Forward Surge Current - Amperes versus
Number Of Cycles At 60Hz - Cycles

Figure 6
Reverse Recovery Time Characteristic And Test Circuit Diagram



- Notes:
1. Rise Time = 7ns max.
Input impedance = 1 megohm, 22pF
 2. Rise Time = 10ns max.
Source impedance = 50 ohms
 3. Resistors are non-inductive