



Changshu Talent  
Semiconductors Co.,Ltd  
Tel:0086-512-52851998  
Fax:0086-512-52153129

# BAS70WX

## Surface Mount Schottky Barrier Diode 200mW

### Features

- Lead Free Finish/RoHS Compliant("P" Suffix designates RoHS Compliant. See ordering information)
- Fast Switching Speed
- Low Turn-on Voltage
- Surface Mount Package Ideally Suited for Automatic Insertion
- PN Junction Guard Ring for Transient and ESD Protection

### Mechanical Data

- Marking :K73
- Polarity: Indicated by Cathode Band
- Epoxy meets UL 94 V-0 flammability rating
- Moisture Sensitivity Level 1

### Maximum Ratings @ 25°C Unless Otherwise Specified

Characteristic	Symbol	Value	Unit
Peak Repetitive Reverse Voltage	$V_{RRM}$		
Working Peak Reverse Voltage	$V_{RWM}$	70	V
DC Blocking Voltage	$V_R$		
RMS Reverse Voltage	$V_{R(RMS)}$	49	V
Forward Continuous Current(Note1)	$I_F$	70	mA
Forward Surge Current @ $t < 1.0s$	$I_{FSM}$	100	mA
Power Dissipation(Note 1)	$P_d$	200	mW
Thermal Resistance(Note 1)	R	625	K/W
Operation Temp. Range	$T_j$	-55 to +125	°C
Storage Temp. Range	$T_{STG}$	-65 to +150	°C

### Electrical Characteristics @ 25°C Unless Otherwise Specified

Charateristic	Symbol	Min	Max	Unit	Test Cond.
Forward Voltage	$V_F$	-----	0.41 1	V	$t_p < 300\mu s$ $I_F = 1.0mA$ $t_p < 300\mu s$ $I_F = 15mA$
Reverse Leakage Current	$I_R$	-----	100	nA	$t_p < 300\mu s$ $V_R = 50V$
Junction Capacitance	$C_j$	-----	2	pF	$V_R = 0V$ , $f = 1.0MHz$
Reverse Recovery Time	$t_{rr}$	-----	5	ns	$I_F = I_R = 10mA$ $I_R = 1.0mA$ , $R_L = 100\Omega$

Notes: 1. Valid provided that terminals are kept at ambient temperature.

### SOD-323

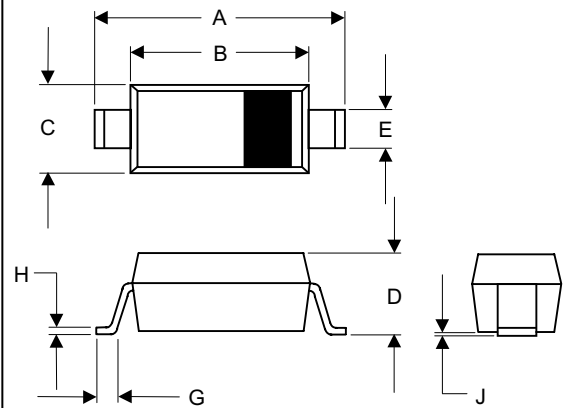

DIM	DIMENSIONS				NOTE
	INCHES		MM		
	MIN	MAX	MIN	MAX	
A	.090	.107	2.30	2.70	
B	.063	.071	1.60	1.80	
C	.045	.053	1.15	1.35	
D	.031	.045	0.80	1.15	
E	.010	.016	0.25	0.40	
G	.004	.018	0.10	0.45	
H	.004	.010	0.10	0.25	
J	-----	.006	-----	0.15	

### SUGGESTED SOLDER PAD LAYOUT

