



Changshu Talent
Semiconductors Co.,Ltd
Tel:0086-512-52851998
Fax:0086-512-52153129

FR101GP THRU FR107GP

Features

- Epoxy meets UL 94 V-0 flammability rating
- Moisture Sensitivity Level 1
- Fast Switching Speed For High Efficiency
- Glass Passivated Junction
- Lead Free Finish/RoHS Compliant (Note1) ("P" Suffix designates Compliant. See ordering information)

Maximum Ratings

Operating Temperature: -55°C to +150°C
Storage Temperature: -55°C to +150°C

Catalog Number	Device Marking	Maximum Recurrent Peak Reverse Voltage	Maximum RMS Voltage	Maximum DC Blocking Voltage
FR101GP	FR101GP	50V	35V	50V
FR102GP	FR102GP	100V	70V	100V
FR103GP	FR103GP	200V	140V	200V
FR104GP	FR104GP	400V	280V	400V
FR105GP	FR105GP	600V	420V	600V
FR106GP	FR106GP	800V	560V	800V
FR107GP	FR107GP	1000V	700V	1000V

Electrical Characteristics @ 25°C Unless Otherwise Specified

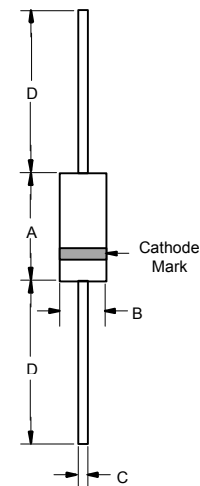
Average Forward Current	$I_{F(AV)}$	1 A	$T_A = 55^\circ\text{C}$
Peak Forward Surge Current	I_{FSM}	30A	8.3ms, half sine
Maximum Instantaneous Forward Voltage	V_F	1.3V	$I_{FM} = 1.0\text{A};$ $T_A = 25^\circ\text{C}$
Maximum DC Reverse Current At Rated DC Blocking Voltage	I_R	5.0 A 100 A	$T_A = 25^\circ\text{C}$ $T_A = 100^\circ\text{C}$
Maximum Reverse Recovery Time FR101GP-104GP FR105GP FR106GP-107GP	T_{rr}	150ns 250ns 500ns	$I_F=0.5\text{A}, I_R=1.0\text{A},$ $I_{rr}=0.25\text{A}$
Typical Junction Capacitance	C_J	15pF	Measured at 1.0MHz, $V_R=4.0\text{V}$

*Pulse Test: Pulse Width 300 sec, Duty Cycle 1%

Note: 1. High Temperature Solder Exemption Applied, see EU Directive Annex 7.

1 Amp Glass Passivated Rectifier 50 to 1000 Volts

DO-41

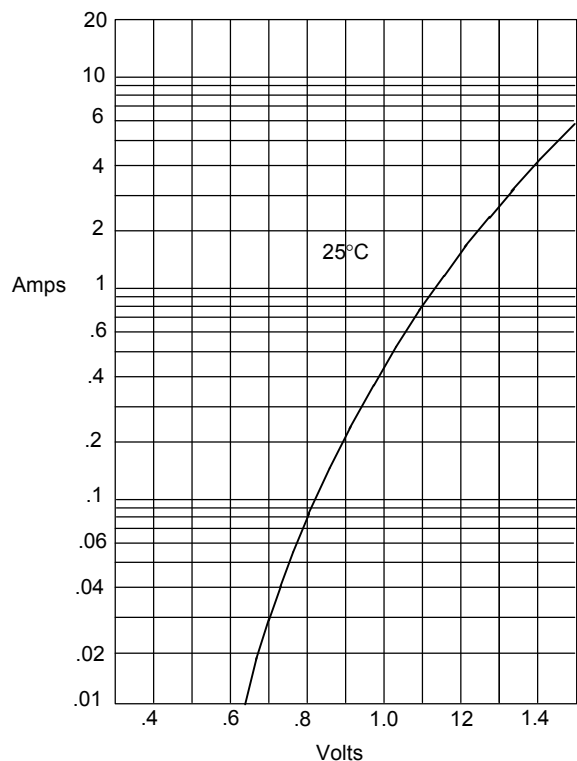


DIM	DIMENSIONS				NOTE
	INCHES		MM		
A	.166	.205	4.10	5.20	
B	.080	.107	2.00	2.70	
C	.028	.034	.70	.90	
D	1.000	---	25.40	---	

FR101GP thru FR107GP

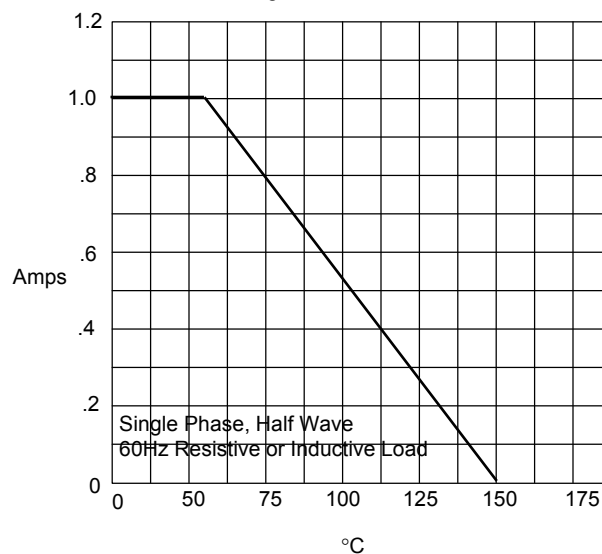


Figure 1
Typical Forward Characteristics



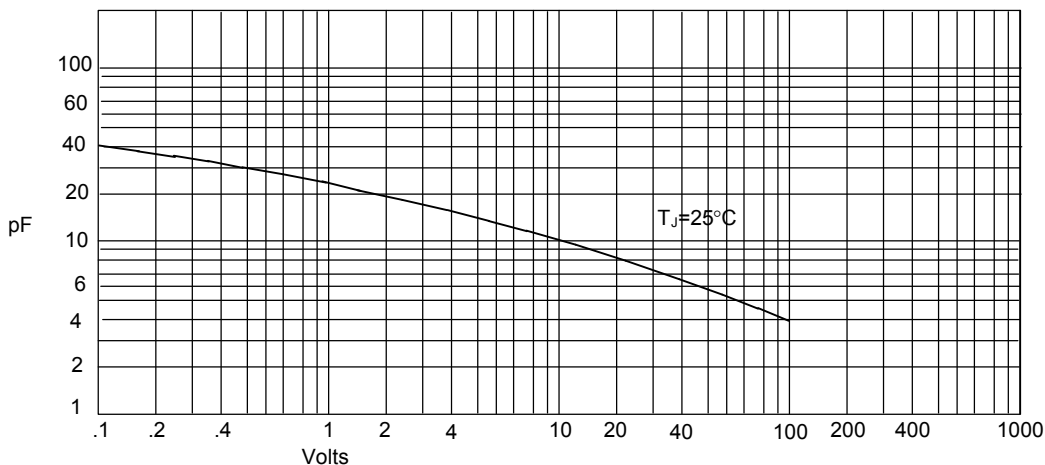
Instantaneous Forward Current - Amperes *versus*
Instantaneous Forward Voltage - Volts

Figure 2
Forward Derating Curve



Average Forward Rectified Current - Amperes *versus*
Ambient Temperature - °C

Figure 3
Junction Capacitance

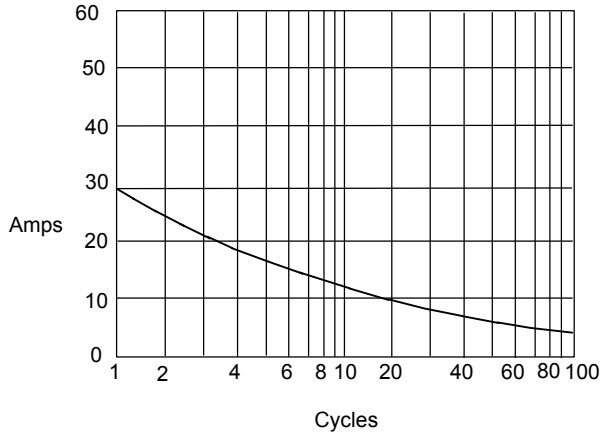


Junction Capacitance - pF *versus*
Reverse Voltage - Volts

FR101GP thru FR107GP

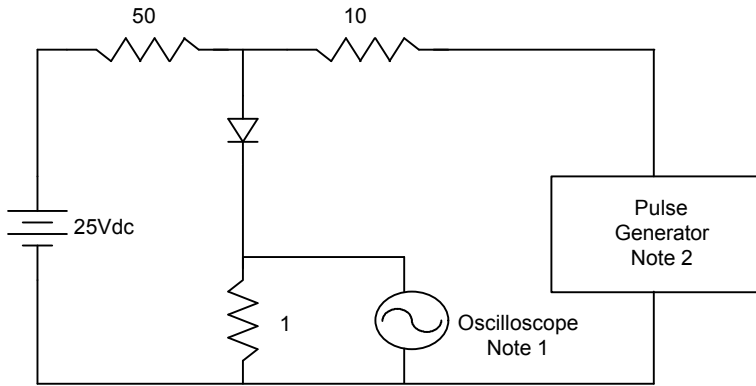


Figure 4
Peak Forward Surge Current



Peak Forward Surge Current - Amperes versus
Number Of Cycles At 60Hz - Cycles

Figure 5
Reverse Recovery Time Characteristic And Test Circuit Diagram



- Notes:
1. Rise Time = 7ns max.
Input impedance = 1 megohm, 22pF
 2. Rise Time = 10ns max.
Source impedance = 50 ohms
 3. Resistors are non-inductive

